



RHINO CHASSIS AUSTRALIA



WARRANTY & SERVICE HANDBOOK

FULLY ENGINEERED AND ADR APPROVED CHASSIS



Rhino Chassis Australia

29 CAPITAL LINK DRIVE CAMPBELLFIELD VIC 3061

Phone: (03) 8313 2939

Email: info@rhinochassisaustralia.com.au

Website: www.rhinochassisaustralia.com.au

RHINO CHASSIS AUSTRALIA: USER GUIDE AND LIMITS OF CARAVAN CHASSIS

Thank you for purchasing an Australian made caravan chassis with Australian made steel. This helps keep jobs in Australia.

Chassis Design

The chassis design and materials used have been tested to meet or exceed the requirements of the Australian Design Rules.

Chassis Components

Rhino Chassis Australia is an important part of this caravan and consists of the coupling (third party), A frame (yoke), flat steel base for caravan structure, corner stabilisers (third party), wheels and tyres (third party), brakes (third party), and suspension (third party). The chassis is identified with a serial number and has a plaque stating the axle group load.

Chassis Maintenance

It is the owner's responsibility to perform proper care of the caravan and chassis. It is strongly recommended to have a major check regularly of the chassis on your caravan. This includes condition assessment and checking that the bolts and wheel nuts are tightened to the appropriate load. Checking of the critical suspension, tyres, wheels, brakes and coupling can be readily conducted by an authorized dealer.

Suspension, Tyres, Brakes and Wheels

Changing or altering suspension components alters the handling characteristics of the caravan. Modern suspension systems have wheel alignment adjustments and the alignment must be regularly checked (see suspension manufacturers manual for guidance). Tyre profiles, size and air pressures also alters the towing performance of the caravan. The brakes assemble (third party) require maintenance and reference to the suspension manufacturers manual is required.

Load Management

The load capacity of your caravan is assigned by the caravan manufacturer. The ATM is the maximum weight load. Do not exceed this weight rating. Doing so could damage your caravan or tow vehicle, and adversely affect handling and braking characteristics. It is the owners responsibility to manage the weight distribution in the caravan and ensure the ATM and the tow ball weight loading are within the limits as specified on the caravan manufacturers VIN plate.

IMPORTANT: For insurance purposes, we highly recommend weighing your loaded caravan before each trip. All load bridge certificates should be kept in a safe place for easy reference.

Waste/Grey water tanks

Whenever possible travel with the minimum water/grey water in the holding tanks. The liquid in the tanks, typically located after the axle, may affect the towing characteristics.

Coupling & Drawbar

The use of an oversize coupling can damage the chassis and changing the original coupling device voids all direct or implied warranties. Refer to the coupling manufacturers manual for maintenance instructions.

Maintaining a level of height of the coupling device and tow ball when connected, by using load levelling/equalizing bars of the coupling assembly and tow ball height adjustment (third party) may be required. A high tow ball height transfers weight to behind the axle and causes the caravan to fishtail at speed increases. A low ball height transfers weight to the tow ball. Refer to manufacturers instruction to adjust the weight-distribution to the proper height. Ensure the weight of the load is below the ATM and the tow ball load is not exceeded.

CAUTION: Load levelling/equalizing bars can be used providing the couplings movement is not obstructed. Clearance should also be checked to ensure the trailer drawbar does not foul, particularly in tight reversing situations.

CAUTION – Vehicles with a towing capacity over 3500kg:

Do not use load levelling/equalizing bars if your vehicle exceeds 3500kg towing capacity. If your vehicles towing capacity exceeds 3500kg, you must use an Air Safe Hitch and a rated off-road coupling.

WARNING: Check the tow vehicles owners handbook to ensure your vehicle, is capable of towing the caravan or trailer. The instructions supplied by the tow vehicle manufacturer must be read, understood, and adhered to at all times. The operator has a responsibility to be familiar with the instructions regarding towing. Non-compliance with the instructions in this user guide, the towing vehicle handbook, or the Law may result in property damage or serious injury.

Jacks and Corner stabilizers

There are dedicated 'jacking points' on the chassis for the location of the jack when changing a wheel. Refer to the manual regarding the position and safe use of the jack. It is recommended the user becomes familiar with jacking up the caravan and changing tyres.

Corner stabilizers are NOT jacks for lifting caravan. They are not jacking points as they are located on the corners of the caravan and can distort the flat floor structure of the chassis. Bent stabilizer legs from overloading will void the warranty of the chassis.

Accessories

There are numerous accessories on the market and each adds to the ATM and limits what you can carry (weight) in the caravan. The location of the load in reference to the axle and tow ball weight is also of concern. It is the responsibility of the owner to secure any accessories and attachments.

Read of Caravan: The rear of the caravan is not designed to carry cargo and accessories such as bike rack or spare wheels that extend past the end of the chassis should be limited to a total of 45kg. Extra weight behind the axle may reduce the tow ball load and dramatically affect the handling.

A Frame (Yoke) of Caravan: The front of the caravan has an A Frame which is not designed to carry cargo. The additional load placed on the A Frame including additional gas bottles, stone guards or tools boxes cannot exceed the maximum allowable tow ball weight on your VIN plate.

Installation: Third party accessories for caravans often require installation to the caravan and occasionally the chassis. Drilling holes for additional screw and bolts, drilling access holes for additional wiring and welding brackets onto critical load carrying structural areas of the chassis are not permitted and will void the warranty. Such installation activities by third parties, increases the risks of cracking, bending or deforming these critical components. This increases the risk of damage to property and personal injury. It is recommended that the caravan supplier or authorized agent, fit the accessories and the receipts are held by the owner as part of the history of the caravan.

Under no circumstances is any repair work to be carried out on the chassis without Rhino Chassis Australia' written approval.

Customers who have repair work carried out without Rhino Chassis Australia' written approval will not be reimbursed or compensated



SUSPENSION SERVICING SCHEDULE (Third Party)

you must follow the suspension manufacturers operating and service manual supplied with the caravan chassis. If you fail to service the product in accordance with the suspension manufacturers operating and service manual, it will void warranty.

INSPECTION & MAINTENANCE CHECKLIST

* These items are considered to be user serviceable.

Third party – must refer to manufacturers manual.

NOTE: These are service functions, not warranty items. The points listed below constitute good, common sense maintenance practice.

COMPONENT	CHECK/ADJUSTMENT REQUIRED
*A Frame and main bearers	Check A Frame and main bearers for permanent distortion, deformation, cracks or separation of components.
*A Frame and chassis	Check painted and/or galvanized finish for damage due to dents, scratches or chips. Prepare affected area and apply zinc rich primer and top coat in accordance with the paint manufactures instructions. Please note: Is it essential to remove any surface corrosion by wire brushing prior to painting.
*Wheel Nuts – Use only a correctly calibrated manual torque wrench	Check for tightness. Please refer to the wheel tightening procedure explained later.
*Tow coupling (#Third Party-Refer to coupling manufacturers manual)	Check coupling and coupling lock for damage and for correct operation. Check coupling mounting bolts to ensure all lock nuts are present and appear tight.
*Park Brake (#Third Party) – you must chock all wheels before applying the handbrake. DO NOT solely rely on the handbrake.	Check cable adjustment by applying the parking brake. The park brake should be fully engaged after a maximum of 6 “clicks.” Use knurled knob on cable to adjust. If correct adjustment cannot be achieved, service and parking brakes must be adjusted as per the brake manufacturers adjustment procedure. Contact your caravan dealer for assistance if required.
*Electric Brakes (#Third Party-Refer to suspension manufacturers manual.)	Check operation.
*Brake wiring (#Third Party-Refer to suspension manufacturers manual.)	Check wires between chassis and brake backing plates to ensure there are no breaks or loose connections.
*Tyres (#Third Party)	Check pressure. Where required, inflate to pressure listed on the trailer identification plate. Check of abnormal or uneven tread wear. If uneven or abnormal wear is present, contact the caravan dealer immediately.
*Jockey wheel and mounting bracket (#Third Party)	Check for damage and rectify as required.
*Safety chains (#Third Party)	Check attachment to A Frame. Check for damage to links due to contact with road surface.
*Shock absorbers (#Third Party-Refer to suspension manufacturers manual.)	Check mounting bolts to ensure locknuts are present and appear tight.
*Suspension mounting bolts (#Third Party-Refer to suspension manufacturers manual.)	Hand/Visual check to ensure bolts and locknuts are present and appear to be tight.
Control arm mounting bolts (#Third Party-Refer to suspension manufacturers manual.)	Hand/Visual check to ensure bolts and locknuts are present and appear to be tight.
*Rocker roller leaf springs & Axle U-bolts (#Third Party)	Check for sagging, distortion, cracking or breakage. Check for broken, misaligned or loose bolts. Check that all nuts & locknuts are present & tight.
*Jacking Points (#Third Party)	Check for damage – Repair as required.



All maintenance must be carried out by component, experienced personnel with access to the necessary tools and equipment (eg correctly calibrated manual torque wrench)

WARNING: Maintenance or repair work carried out by inexperienced untrained and/or inadequately equipped personnel may result in property damage or personnel injury. All other procedures must be carried out by approved persons or workshops. If in doubt, the caravan owner should always seek assistance from a specialist caravan service and repair workshop.

WHEEL NUT TORQUE SETTINGS FOR TRAILER APPLICATIONS

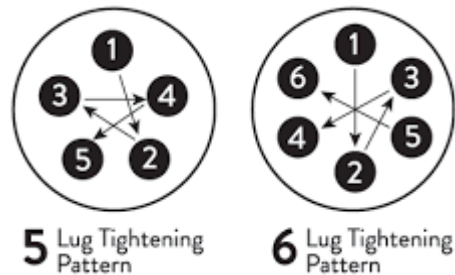

It is important to maintain proper torque specifications to provide safe and secure attachment of the wheel to the hub drum.

* Start all nuts by hand to prevent cross threading.

* Tighten nuts in three stages using a cross star pattern.

* Whenever wheels are removed and refitted the wheel nut torque should be checked. Wheel nuts should be tightened to the torque specified by the wheel manufacturer – 140 Nm (newton meters)

* Always use a correctly calibrated manual torque wrench to check wheel nut torques.

WARNING: Do not use an impact/rattle gun to tighten wheel nuts. The wheel manufacturer recommends the wheel nut tension to be checked every 100kms for the first 400kms of your initial trailer use.

WARNING: Incorrectly tightened or neglected wheel nut tension may result in wheel loosening and/or detachments. Consequences may include property damage, personal injury or death. If you have any concerns in relation to wheel nut tension, you should contact a professional immediately. A correctly calibrated manual torque wrench should be used for this work.

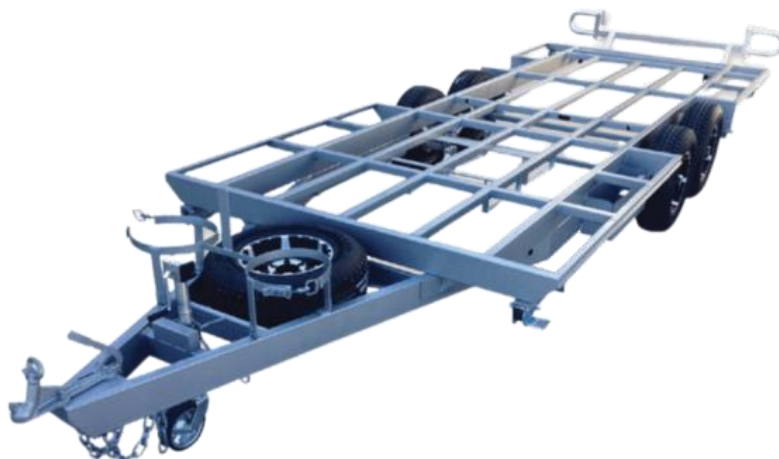

RHINO CHASSIS AUSTRALIA WARRANTY

Our goods come with guarantees that cannot be excluded under the Australian Consumer Law. You are entitled to a replacement or refund for major failure and for compensation for any other reasonably foreseeable loss or damage. You are also entitled to have the goods repaired or replaced if the goods fail to be acceptable quality and the failure does not amount to major failure.

Rhino Chassis Australia (ABN) 68 664 397 371 of 29 CAPITAL LINK DRIVE CAMPBELLFIELD VIC 3061 provides the following warranty in relation to its chassis (Chassis)

The benefits of this warranty are in addition to any rights and remedies imposed by Australian State and Federal legislation that cannot be excluded. Nothing in this warranty is to be interpreted as excluding, restricting or modifying and State of Federal legislation applicable to the supply of goods and services which cannot be excluded, restricted or modified.

WARRANTY

Rhino Chassis Australia warrants that subject to the exclusions and limitations below, all parts of the manufacture and assemble of the Chassis carried out by Rhino Chassis Australia will be free from defects in materials and workmanship for a period of 5 years from date of purchase (**Warranty Period**) under normal use and operation within Australia provided that:

- (a) The goods have not become defective as a result or consequence of the owners failure:
 - i. To properly maintain, use or operate the goods in accordance with all recommendations and instructions of Rhino Chassis Australia User Guide and the caravan manufacturer, and the capacity and operating limitations specified by Rhino Chassis Australia and the caravan manufacturer; or
 - ii. To have the caravan, including its chassis and suspension, properly, regularly and punctually services in accordance with the instructions and recommendations specified for the goods by the suspension manufacturer and the caravan manufacturer.

If a defect appears in Rhino Chassis Australia' manufacture or assembly of the Chassis before the end of the Warranty Period and Rhino Chassis Australia finds the Chassis to be defective in materials or workmanship, Rhino Chassis Australia will, in its sole discretion, either:

- (a) Repair the Chassis or the defective part of the Chassis free of charge; or
- (b) Cause the Chassis or the defective part of the Chassis to be replaced or repaired by a qualified repairer free of charge.

Rhino Chassis Australia reserves the right to replace defective parts of the Chassis with parts and components of similar quality, grade and composition where an identical part or component is not available. Chassis presented for repair may be replaced and refurbished Chassis parts for the same type rather than being repaired. Refurbished parts may be used to repair the Chassis.

Under no circumstances is any repair work to be carried out on the chassis without Rhino Chassis Australia' written approval. Customers who have repair work carried out without Rhino Chassis Australia' written approval will not be reimbursed or compensated.

EXCLUSIONS

Rhino Chassis Australia warranty will not apply where:

- (a) The Chassis has been repaired, altered or modified by someone other than Rhino Chassis Australia or and authorized repair agent of Rhino Chassis Australia;
- (b) The alleged defect in the Chassis is, in fact not a defect because it is within the acceptable industry variances
- (c) Rhino Chassis Australia cannot establish any fault in the Chassis after testing and inspection;
- (d) The Chassis has been used for a purpose apart from the purpose for which it was designed and manufactured;
- (e) The defect in the Chassis has arisen due to the customers failure to properly use, service or maintain the Chassis in accordance with the caravan manufacturers user manuals and all other manuals;
- (f) The defect in the Chassis has arisen due to the customer's request to customize the Chassis;
- (g) The Chassis has been subject to abnormal conditions, including environment, temperature, water, fire, humidity, pressure,



stress;

(h) The defect has arisen due to abuse, misuse, neglect or accident;

(i) Unauthorised parts or accessories have been used on or in connection with the Chassis;

(j) The Chassis has been overloaded or involved in an accident; or

(k) The defect has arisen as a result of the manner in which the caravan or any other element relating or ancillary

there to has

been affixed to the Chassis.

The warranty does not extend to:

(a) Damage or defects caused by normal wear and tear, including impact or stone damage;

(b) Water damaged caused by creek crossings, flooding and other similar conditions;

(c) Damage or defects caused by excessive speed, hard impact or use of the Chassis in unsuitable 4WD or off-road applications;

(d) The aesthetics of galvanizing, coating and protectant treatments used;

(e) Surface rust or degradation from environmental factors;

(f) Tyre wear; or

(g) Suspension alignment

Items not covered by Rhino Chassis Australia Warranty are as follows:

(a) Maintenance costs and wear and tears items including wheel balance and adjustment, brake adjustment, removal of rattles and squeaks and the general tightening up of components, addition of Lubricants, repair/rectification of paint damage, chips, dents, scratches and marks, repair/rectification of damage to galvanizing (where applicable) including chips, dents, scratches and marks.

(b) Corrosion arising as a result of chips, dents, scratches and marks.

(c) Any corrosion or surface rust.

(d) Damage caused by overloading or incorrect load distribution.

(e) Damage caused by use in off-road applications or over rough roads and terrain where the caravan is not designed and equipped for such operation.

(f) Damage caused by improper use of load levelling devices (e.g.: using a load levelling device to correct the front to rear altitude and/or towing behavior of an incorrectly laden caravan and/or towing vehicle).

(g) Tyre replacement due to normal wear, damage such as cuts, snags, bruises and bulges, damages caused by punctures or tyre repair, damage caused by improper inflation or alignment, speeding, overloading or improper mounting or dismantling.

(h) Damage due to impact with objects, persons, animals or other vehicle(s) unless it can be shown that the impact was directly attributable to a defect in materials or workmanship covered by the Rhino Chassis Australia Warranty.

(i) Goods supplied by third parties – These include wheel caps, wheels, tyres, jockey wheels, couplings, springs, axles, wheel bearings, brakes, wheel hubs, wheel nuts, wheel studs and shock absorbers.

(j) Damage resulting from and directly attributable to any work performed by the caravan manufacturer.

(k) Damage resulting from any failure of the caravan manufacturer to properly inspect and service the caravan prior to delivery to the customer. It is expected that checklists or other documentary evidence will be provided to and retained by the customer upon completion of this pre-delivery service and inspection.

(l) Damage to shock absorbers due to overheating, eg: towing over rough terrain for extended periods with inadequate cooling off periods. Note: It is recommended by the suspension manufacturer, that the minimum rest period be 45 minutes per 2 hours travel.

(m) Damage caused by the use of an inappropriate tow vehicle leg which has insufficient towing capacity, or the use of a tow vehicle having a gross vehicle mass exceeding 3.5 tons (unless your chassis is designed and constructed for use with a vehicle up to 4.5 tons GVM).



(n) Damage due to the use of a tow vehicle which is equipped with an inadequate or unsuitable tow bar, tow hitch or coupling.

(o) Damage due to the owners failure to correctly connect the tow vehicle to the goods being towed.

(p) Any undesirable towing characteristics arising as a direct result of the caravan manufacturers layout of items such

as

furniture, fittings, fixtures and appliances.

WARRANTY CLAIMS PROCEDURE

1. If a fault covered by this warranty occurs, the customer must first contact the dealer from which the caravan was purchased. The dealer will contact the Caravan manufacturer and then they will contact Rhino Chassis Australia on your behalf.
2. Any warranty claim must be accompanied by:
 - (a) Proof of purchase;
 - (b) Full details of the alleged defect; and
 - (c) Appropriate documentation (such as historical service maintenance records, VIN plate details and weighbridge certificates) dealing with the manufacturing of the caravan, its use and maintenance.
3. The customer must make the Chassis available to Rhino Chassis Australia or its authorized repair agent for inspection and testing. If such inspection and testing finds no defect in the Chassis, the customer must pay Rhino Chassis Australia' usual costs of inspection and testing.
4. The customer must bear the costs of the transport of the Chassis to and from Rhino Chassis Australia or the authorized repair agent, and all insurance of the Chassis.

SUPPLIED COMPONENTS

Some of the materials and components used in the manufacture of the Chassis are not manufactured by Rhino Chassis Australia and are not covered by this warranty. Instead, they may separately warranted by their individual manufacturer's warranty against manufacturing defects. Rhino Chassis Australia will use its best endeavors to pass on to the customer the benefit of any third-party manufacturer's warranties. Please note that the length of warranty periods provided for the supplied components and their terms may vary depending on the item.

The separately warranted components may include, but are not limited to, axles, wheels and couplings.

MAINTENANCE ITEMS

The warranty does not apply to maintenance items which are the responsibility of the customer. The maintenance items include but are not limited to:

1. Suspension service and wheel alignment;
2. Wheel bearing servicing and adjustment;
3. Checking tyre pressures;
4. General greasing and tightening of components;
5. Hand brake adjustment;
6. Rust-proofing, painting and maintenance of painted surfaces and exposed surfaces;
7. Checking wheel nut tension;

LIMITATIONS

Rhino Chassis Australia makes no express warranties or representations other than set out in this warranty.

The repair of the Chassis or part of the Chassis is the absolute limit of Rhino Chassis Australia' liability under this express warranty.

INDEMNITY

By purchasing the caravan, you indemnify us against all Liabilities and Claims arising from any defect in the caravan wholly or partly arising from your manufacture, assembly or fabrication of the caravan except to the extent that the defect was caused by the breach of warranty or negligence of Rhino Chassis Australia.

DEFINITIONS

"Claims" means a claim, action, damage, loss, cost, expense or Liability incurred by or to or made or recovered by or against any person, however arising, whether present, immediate, future or contingent.

"Liabilities" means all liabilities (whether actual, contingent or prospective_ losses, damages, costs and expenses of whatever description.

